

TEMPERATURE SENSOR TYPE CT GE1

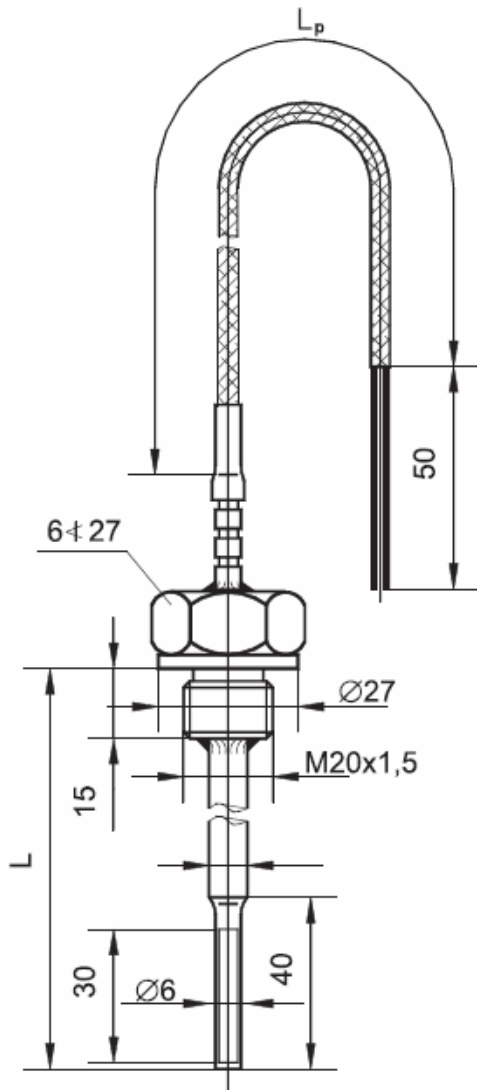

TECHNICAL DATA:

1. Measuring temperature range:
Pt: -50 ... 180 [°C]
2. Material of wetted parts:
304ss or 316Lss
3. Standard cable length / cable type:
 $L_p=1000$ [mm] (*) / copper braided copper wire
4. Time constant:

Type of sensor	$T_{0.5}$ [s]	$T_{0.9}$ [s]
CT GE1	≤ 3	≤ 9

5. Standard immersion length L:
85, 120, 200 [mm] (**)

APPLICATION:

The sensor is designed for measuring temperature and being installed directly in pressure tanks or industrial pipelines.

EXAMPLE OF ORDER:

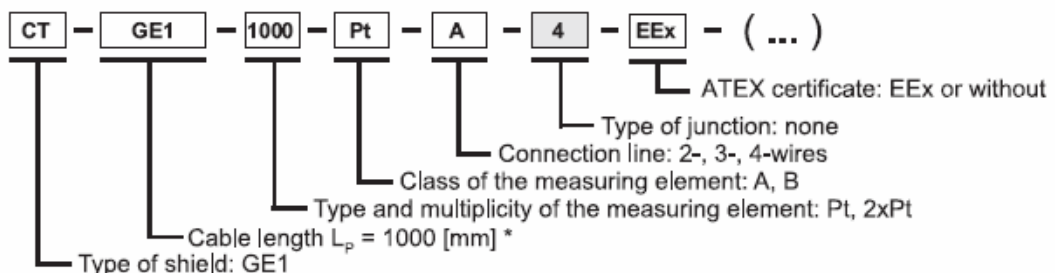

ADDITIONAL INFORMATION:

- 1.* Non-standard length of temperature sensors on demand.
2. Standard thermometric resistor Pt100. In case of ordering Pt500 or Pt1000, please specify this information in brackets.
- 3.** The length of shield should also be specified in brackets, i. e.:

CT - GE1 - 1500 - 2xPt - B - 2 - EEx - (400; Pt500)