

TEMPERATURE SENSOR TYPE CT 1068 + OG

TECHNICAL DATA:

1. Measuring range:
Pt: 0 ... 150 [°C]
2. Material of wetted parts:
304ss or 316Lss
3. Standard cable length / cable type:
 $L_p=1000$ [mm] (*) / silicone isolated wire
4. Time constant:

Type of sensor	$T_{0.5}$ [s]	$T_{0.9}$ [s]
CT 1068 + OG...	≤ 6	≤ 17

5. Standard immersion length L:
85, 120 [mm] **

APPLICATION:

The sensor is designed for measuring the temperature of gases, liquids and solids, especially loose solids. The CT 1068 temperature transmitter with additional shield OG ensure leakproof and resistance, can be installed in pipelines and pressure tanks.

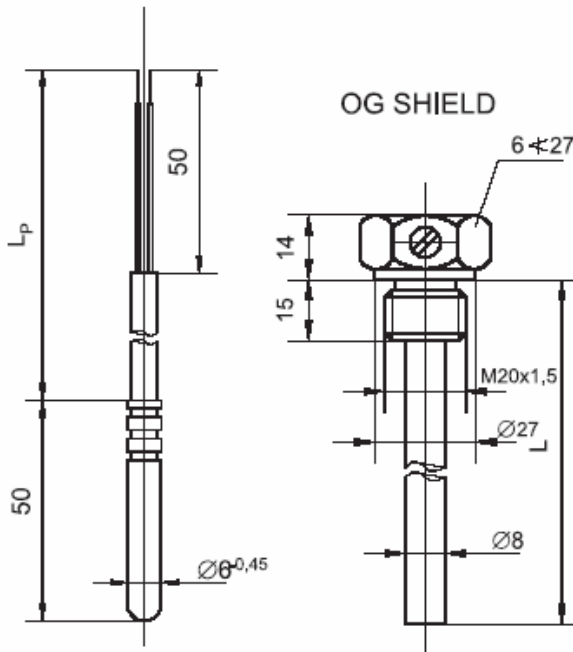

EXAMPLE OF ORDER:

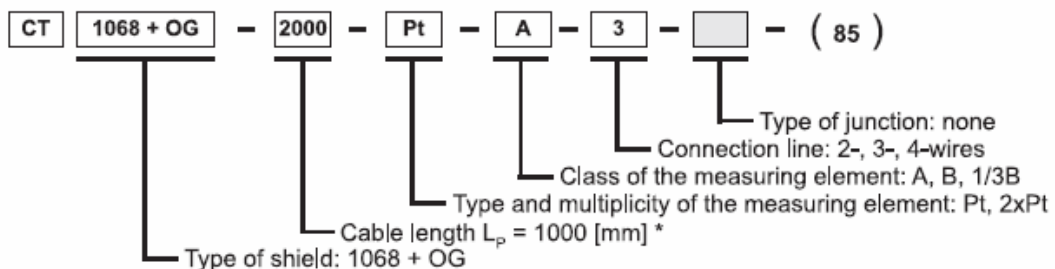

ADDITIONAL INFORMATION:

1. * Non-standard length of temperature sensors on demand.
2. The mounting length of the OG shield: 50, 70, 90, 110, 160 [mm] should be indicated in brackets. Otherwise we perform only the CT1068 sensor.
3. Standard thermometric resistor Pt100. In case of ordering Pt500 or Pt1000, please specify this information in brackets.

CT 1068 + OG - 1000 Pt - B 2 - (L=160; Pt500)