

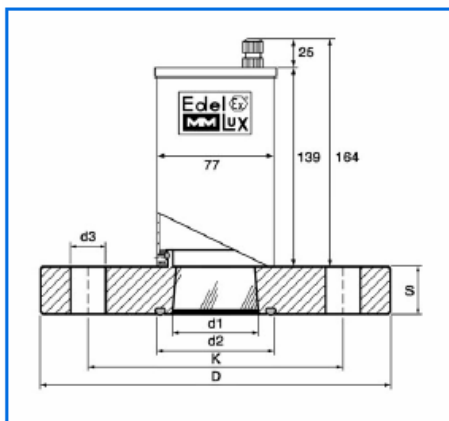

Hazardous sightglass light fittings from stainless steel for sterile applications
Series EdelEx 5 dH / 10 dH / 20 dH on metal fused sightglass flanges for sterile processes



Sightglass light fitting type EdelEx STERI-LINE 20 dH, 24 V, 20 W, EEx d IIC T4, Ex II 2 G + D, on metal fused sightglass flange



Dimensions with mounted sightglass light fitting

Branch office / exclusive agent:

Application:

On metal fused sightglass flanges for mounting onto

- base flanges to DIN 28117 or similar
- weldnecks with flat face

for the optimal illumination of small and pilot reactors as well as vessels for sterile and aseptic applications, mainly in the pharmaceutical, biotechnological, cosmetic and food processing industries.

IMPORTANT: Only for use with parallel flat face flanges without seal recess. We recommend the use of Belleville spring washers, 2 pcs. for each connection hole.

Advantages:

- Brilliant and glare free illumination
- Extremely small dimensions
- Aseptic
- High security
- Easy installation
- CIP and SIP cleaning possible

Light fitting series EdelEx STERI-LINE (for use in hazardous areas):

Supply: AC or DC (with integrated transformer AC only)
 24, 36, 42, 115, 230, 240 V with integrated transformer (5, 10 W)
 12, 24 V without integrated transformer (20 W)

Power: 5, 10, 20 W

Housing: Stainless steel

Protection mode: IP 65, dust and spray water tight to EN 60529 / DIN VDE 0470 part 1

Ignition protection type: EEx d

Explosion group: IIC

Temperature classes: T4 (10 and 20 W), T6 (5 W)

ATEX: Ex II 2 G + D, T 130 °C (T 80 °C in version T6)

For more technical details see data sheet EdelEx 5 dH / 10 dH / 20 dH

Metal fused sightglass flange:

Approvals:

TÜV-approval to the pressure vessel guideline as part of a pressure vessel (for material duplex stainless steel 1.4462)

Technical data:

- Test base: DGRL 97 / 23 / EG, AD 2000 standards, DIN 7079-1 May 1999
- Materials to VdTÜV specifications and the respective DIN/EN standards
- Glass quality: Borosilicate glass to DIN 7080

Certificates:

- To be supplied against extra charge to DIN EN 10204

Operating conditions:

- Pressure: -1 to 16 bar
- Temperatures:

Ring materials:	1.4462:	-30 °C to +280 °C
	2.4602:	-60 °C to +300 °C
	2.4605:	-60 °C to +300 °C
	2.4610:	-60 °C to +300 °C

Dimensions:

DN	PN	D	K	S	d1	d2	d3	Number of holes	O-Ring*	Spring washer*
50	16	165	125	21	38	66	18	4	58,74 x 3,53	31,5/16,3x1,25
65	16	185	145	23	38	86	18	4	78,97 x 3,53	31,5/16,3x1,25

* Not contained in our delivery

All dimensions in mm. Subject to changes without preliminary notice.