

## FLUSH DIAPHRAGM

ANC4B 316 stainless steel or black anodised aluminium switchcase to IP66 standards.

Calibrated adjustment scale.

Settings from 0.1 to 16 Bar.

Single or dual microswitch option.

Wetted parts NACE MR-01-75 compliant.

### ATEX Flameproof Version

CE  II2GD EExd IIB + H<sub>2</sub> T6 & T5

T6 Tamb -55 to +60°C, T6 +75°C

T5 -55 to +90°C

### ATEX Intrinsically Safe Version

CE  II1GD EEx ia IIC T6, T5 & T4

T6 Tamb -50 to +78°C, T5 +93°C

T4 -50 to +128°C

## PF261 TITAN ATEX EExd, EExia CERTIFIED & INDUSTRIAL PRESSURE SWITCH



This range incorporates a flush diaphragm and is suitable for settings up to 16 Bar. It has been designed for use on processes involving mediums of a high viscosity level or containing suspended solids which would otherwise clog conventional recessed diaphragm models. Resistors can be incorporated for 'end of line' and short circuit monitoring. For specification and introduction to the Titan switch range refer to pages 46 & 47.

ADJUSTMENT RANGE (BAR G)	ADJUSTMENT RANGE (PSI)	MAX WORKING PRESSURE (BAR G)	DEADBAND FIXED (BAR G)	SPRING CODE	DIAPHRAGM CODE
0.1 - 3.1	2 - 44	12	0.35	B	32
2 - 16	30 - 230	40	1.6	B	15

Manufacturer catalogue page 50

PART NUMBER BREAKDOWN		
<b>B</b> = ATEX EExd CERTIFIED <b>O</b> = ATEX EExia CERTIFIED <b>A</b> = INDUSTRIAL  <b>A</b> = ALUMINIUM CASE <b>S</b> = ST. STEEL CASE  <b>1</b> = STANDARD	<b>DIAPHRAGM MATERIAL</b> <b>2</b> = VITON (STANDARD) <b>1</b> = NITRILE  SPRING CODE (SEE RANGE SHEET)	<b>X</b> = COVER PLATE (STANDARD)  ELECTRICAL ENTRY <b>A</b> = M20 STRAIGHT <b>B</b> = M20 ANGLED <b>C</b> = 1/2" NPT STR. <b>F</b> = M25 STRAIGHT
<h2>PF261S1B/2BF15B/15FS2XA</h2>		
<b>1</b> = 1 x SPDT SWITCH <b>2</b> = 2 x SPDT SWITCH  DUAL SWITCHES ARE MECHANICALLY LINKED TO PROVIDE DPDT SWITCHING ACTION	DIAPHRAGM CODE	BS4504 FLANGE 2" 316 ST.ST. <b>FS2</b> = PN40 FLANGE <b>FS0</b> = SPECIAL - SEE TEXT OTHER SIZES AVAILABLE

### SPECIFICATION

**Wetted parts** : 316 St. steel

**Process connections** : 2" BS4504  
PN40 Flange. Other sizes available.

**Diaphragm** : Nitrile or Viton

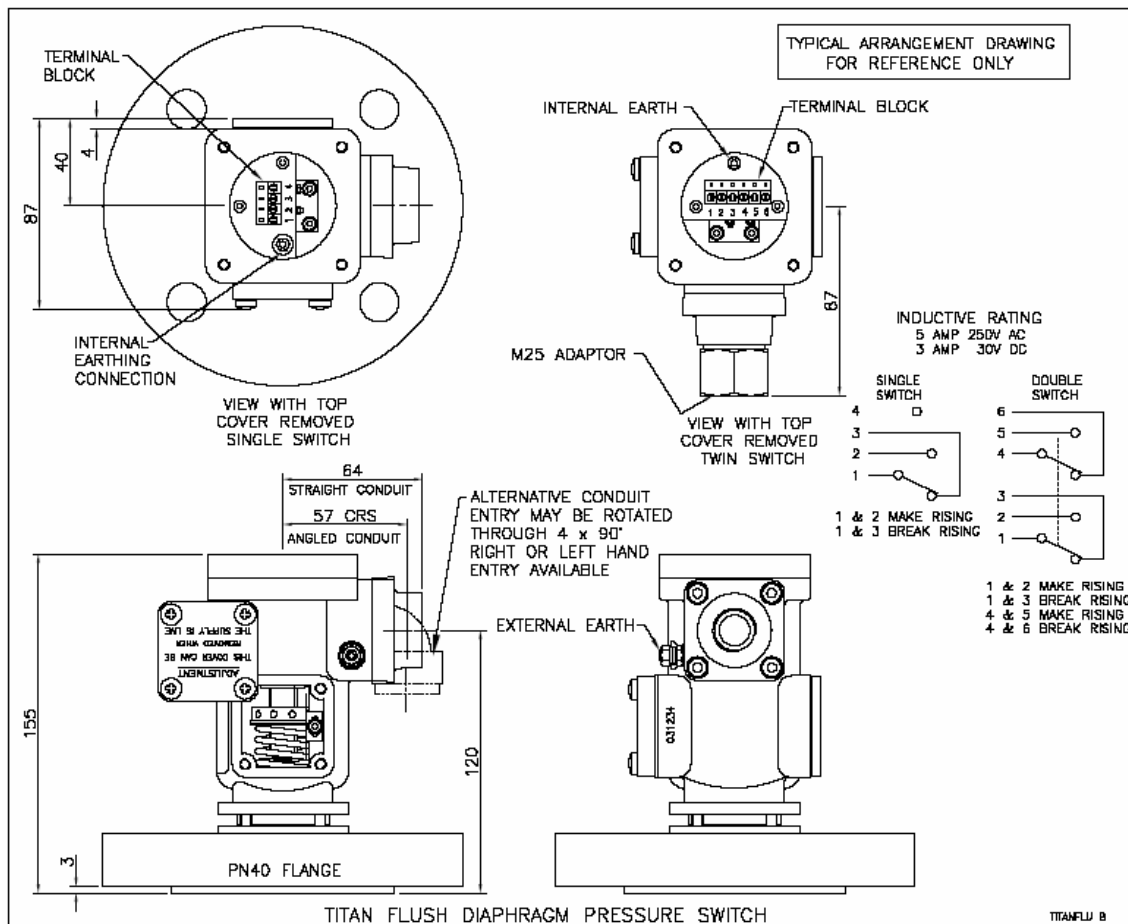

Manufacturer catalogue page 51

## TITAN (XPB) ATEX EExd, EExia INDUSTRIAL SWITCHES

### INTRODUCTION

The Titan **pressure, differential pressure, temperature, level and flow** switches are designed for use in environments where explosive gases and dust can be present (e.g. Gas fields, oil rigs and chemical plants etc.) and have been ATEX certified for CAT 1 EExia IIC T6, T5 & T4 and CAT 2 EExd IIB +H<sub>2</sub> T & T5.

Please note, our EExd switches are available with three maximum ambient temperature options, T6 + 60°C which is standard, T6 + 75°C & T5 + 90°C. Cable selected by customer upon installation should be suitable for ambient temperature, label for + 75°C states cable suitable for 85°C must be used and + 90°C states a 100°C requirement for cable.

These switches are manufactured from a high quality casting which offers robust construction and protection to IP66 for use within heavily polluted industrial and marine environments. A special feature of the instruments is the separation of the flameproof and adjustment compartments allowing for safe on-site adjustment of the set point with power on and the switch in operation.

The Titan range has been certified for mounting against a flush wall or bulkhead via the fitted bracket, therefore the flamepath minimum distances specified in BS EN60079-14:1997 are not applicable.

### CALIBRATION

The design features a simple form of calibration adjustment against a scale plate. This allows users to either order units with a specific setting, or stock a mid range setting and then adjust to suit the application. This can be set safely with the switch supply live. On removal of the adjustment cover the adjusting ring can be turned with a small Tommy bar or Allen key. The setting is read from the centre of the red pointer ring against the calibrated scale plate. Rotation to the left will increase the set point and to the right decrease the set point. The adjustment mechanism incorporates a friction device to ensure set point will not change under vibration conditions.

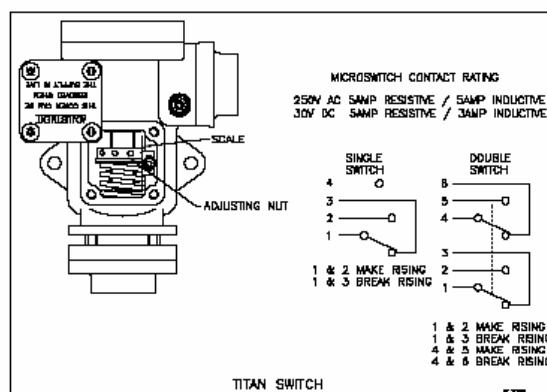

When we are requested to supply switches set at a specific point we can guarantee setting accuracy of less than 2%.

Manufacturer catalogue page 46

## TECHNICAL SPECIFICATION

**Switchcase and covers** : ANC4B 316 stainless steel or black anodised aluminium switchcase.

**Microswitch** : 1 x SPCO/SPDT or 2 x SPCO/SPDT mechanically linked to provide DPDT switching action, reset of switches could be up to 3% apart, dual microswitches may increase deadband by a factor of two.

**Contact material** : Gold plated silver contacts.

**Microswitch rating** :

5 Amps @ 250 VAC resistive and inductive.

5 Amps @ 30VDC resistive, 3 Amps @ 30 VDC inductive.

**Electrical connections** : Terminals suitable for cable 0.5 - 2.5 mm<sup>2</sup>.

**Electrical Conduit Entry** : M20 x 1.5 or 1/2" NPT.

**Environmental Protection** : Switches have been tested and certified by an external test house to IP66 in accordance with BS EN 60529 : 1992.

**Vibration and shock parameters** : Switches were subjected to Ministry of Defence Type Approval System Test Vibration DGS 350 Paras 0602 & 0603. Shock – BR3021.

**Temperature Limitations** : Pressure, Vacuum and Differential Pressure

**Ambient** : -40 to +125°C (standard) -50 to 85°C (special)

**Process** : Diaphragm actuated -50 to +90°C (Nitrile) or -20 to +150°C (Viton).  
Piston actuated -40 to 120°C (Nitrile) or -20 to +150°C (Viton).

**Storage** : -60 to +80°C

(for temperature, level and flow switches please refer to specific pages).

**Certification** : All switches are CE certified and marked in accordance with the following EU directives

Industrial : 73/23/EEC Low Voltage Directive

EExia : 94/9/EC ATEX coded CE II 1GD EExia IIC for CAT 1 (Zone 0) areas

EExd : 94/9/EC ATEX coded CE II 2GD EExd IIB + H<sub>2</sub> for CAT 2 (Zone 1) areas

**Accuracy** : +/-1% at 20°C



XPB XPB/R T6

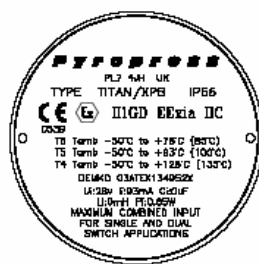

IS



Manufacturer catalogue page 47