

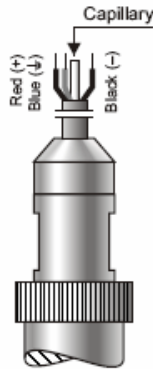

## Hydrostatic level probe PCE-28P

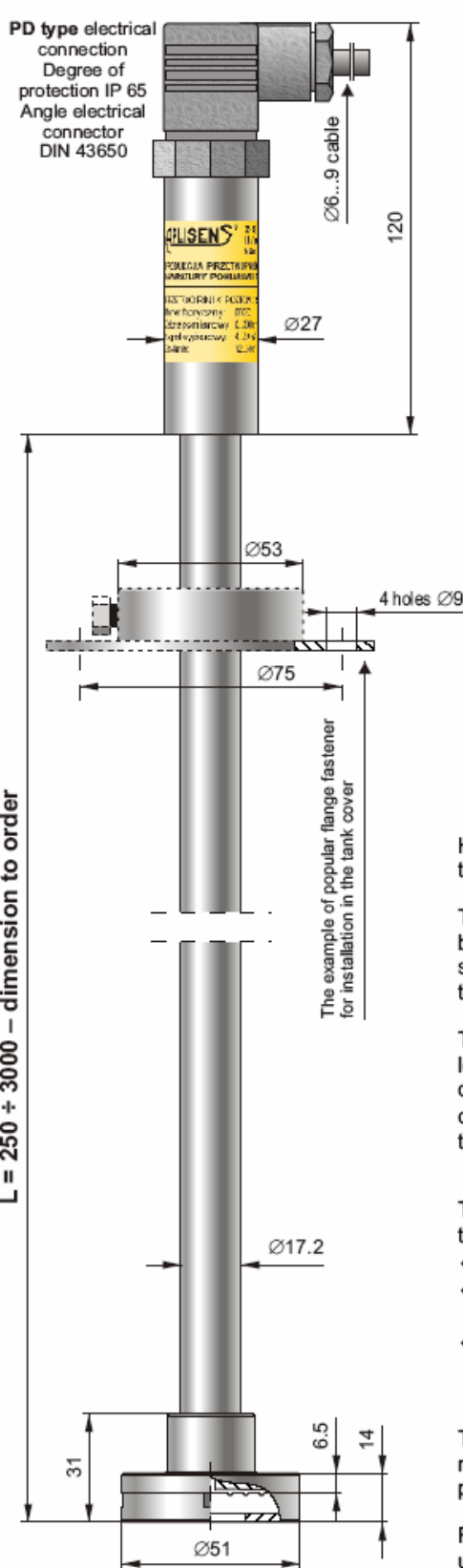

**PCE-28P probe, PK type electrical connection**  
 Degree of protection IP 67  
 The cable electrical connection, contact with the atmosphere through the capillary inside the cable. The cable length 3m (other cable lengths available, if required)

- ✓ Any measuring range from 0...200 to 0...3000 mm H<sub>2</sub>O
- ✓ ATEX Intrinsic safety  II 1/2G EEx ia IIC T4/T5/T6 IM1 EEx ia I

### Application and construction

Hydrostatic level probes are applicable to measure levels of liquids in open tanks, channels, measuring constrictions of open channels, streams etc.

The probe measures the levels of liquid basing on the simple relationship between the height of a liquid column and the resulting hydrostatic pressure. The pressure is measured at the level of the separating diaphragm of the compensated sensing element

The signal is standardized by an electronic amplifier situated above the level of the medium in a casing with degree of protection IP 65 or IP 67, depending on the type of electrical connection used. The electrical wires connecting the amplifier to the sensor are placed inside a  $\varnothing 17.2 \times 1.6$  tube, which is a structural element of the probe.

### Installation, method of use

The probe may be installed in any manner subject to the following conditions:

- ◆ the probe should be fitted via the  $\varnothing 17.2$  tube;
- ◆ the expected maximum level of liquid may not cause flooding of the electronic circuits;
- ◆ if a flange fastener is to be used to install the probe in the tank cover, it should be ordered alongside with the probe, as these fasteners are to be mounted during the probe manufacturing.

The probe does not require special maintenance. Contaminants may be removed from the diaphragm simply by dissolving of the deposits. The diaphragm must not be cleaned mechanically.

For periodic calibration, the user may change the zero point and range using potentiometers with no interaction between the settings.

## Technical data

Any measuring range from 0...200 to 0...3000 mm H<sub>2</sub>O

	Measuring Range	
	0...200 ÷ 500 mm H <sub>2</sub> O	0...700 ÷ 3000 mm H <sub>2</sub> O
Accuracy	0.25%	0.16%
Thermal error of zero	Typical 0.3% / 10°C max 0.5% / 10°C	Typical 0.2% / 10°C max 0.3% / 10°C
Thermal error of span	Typical 0.2% / 10°C max 0.3% / 10°C	Typical 0.2% / 10°C max 0.3% / 10°C

**Long term stability** ≤ (1.5 mmH<sub>2</sub>O + 0.16% FSO)/year

**Hysteresis, repeatability** 0.05%

**Thermal compensation range** 0 ÷ 25°C – standard,  
-10 ÷ 70°C – special version

**Medium temperature limit** -25 ÷ 80°C

CAUTION: the medium must not be allowed to freeze in the immediate vicinity of the sensing element

## Electrical parameters

**Output signal** 4 ÷ 20 mA (two wire transmission)

**Load resistance**  $R[\Omega] \leq \frac{U_m[V] - 10.5V}{0.02A}$   
(for 4 ÷ 20 mA output)

**Power supply** 10.5 ÷ 30 V DC (EEx 12...28 V DC)

**Error due to supply voltage changes** 0.005% / V

**Material of the wetted parts** 00H17N14M2 (316Lss)

**Material of casing** 0H18N9 (304ss)

## Special versions, certificates

- ◇ EEx – ATEX Intrinsic safety
- ◇ -10 ÷ 70°C – extended thermal compensation range
- ◇ Others

## Electrical diagram

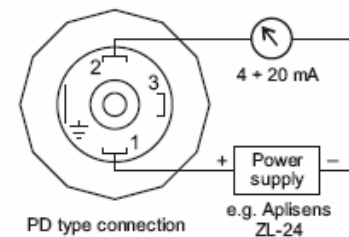

## Ordering procedure

PCE-28P / / ÷ / / L = ... m

Special versions: EEx,  
-10 ÷ 70°C, others – description

Start of measuring range,  
in relation to 4 mA output

End of measuring range,  
in relation to 4 mA output

Type of electrical connection: PD, PK

Tube length

**Example:** PCE-28P level probe / EEx version, extended thermal compensation range / measuring range 0 ÷ 1500 mm of fuel oil with density  $\rho = 0.83 \text{ g/cm}^3$  / electrical connection / tube length 2.2 m

**PCE-28P / EEx, -10 ÷ 70°C / 0 ÷ 1500 mm ( $\rho = 0.83$ ) / PD / L = 2.2 m**