

## Smart level probes SGE-25.Smart and SGE-25S.Smart



Aplisens  
KAP-02  
communicator

- ✓ Programmable zero shift, range and damping ratio
- ✓ 4...20 mA output signal + HART protocol
- ✓ Accuracy 0.1%
- ✓ Integrated internal overvoltage protection circuit
- ✓ ATEX Intrinsic safety  $\text{Ex}$  II 1G EEx ia IIC T4/T5/T6 I M1 EEx ia I

### Application

The SGE-25.Smart level probe is applicable to measure liquid levels in tanks, deep wells or piezometers.

The SGE-25S.Smart probe is applicable to measure levels of liquids containing contaminants or suspensions. A typical use for this probe is the measurement of levels of liquid waste in intermediate pumping stations, fermentation chambers, settling tanks etc.

### Principles of operation, construction

The probe measures liquid levels, basing on a simple relationship between the height of the liquid column and the resulting hydrostatic pressure. The pressure measurement is carried out on the level of the separating diaphragm of the immersed probe and is related to atmospheric pressure through a capillary in the cable.

The active sensing element is a piezoresistant silicon sensor separated from the medium by an isolating diaphragm. The electronic amplifier, which works in combination with the sensor, is additionally equipped with an overvoltage protection circuit, which protects the probe from damage caused by induced interference from atmospheric discharges or from associated heavy current engineering appliances.

### Configuration

The following metrological parameters can be configured:

- ◆ The units of pressure;
- ◆ Start and end-points of set range;
- ◆ damping time constant;
- ◆ inverted characteristic (output signal 20 + 4 mA).

### Calibration

It is possible to calibrate the probe in relation to a model pressure.

### Communication

The communication standard for data interchange with the probe is the Hart protocol.

Communication with the probe is carried out with:

- a KAP-02 communicator,
- some other Hart type communicators,
- a PC using an RS-HART converter and RAPORT-01 configuration software.

The data interchange with the probe also enables the users to:

- ◆ identify the probe;
- ◆ read the currently measured hydrostatic pressure value, output current and percentage of measuring range.

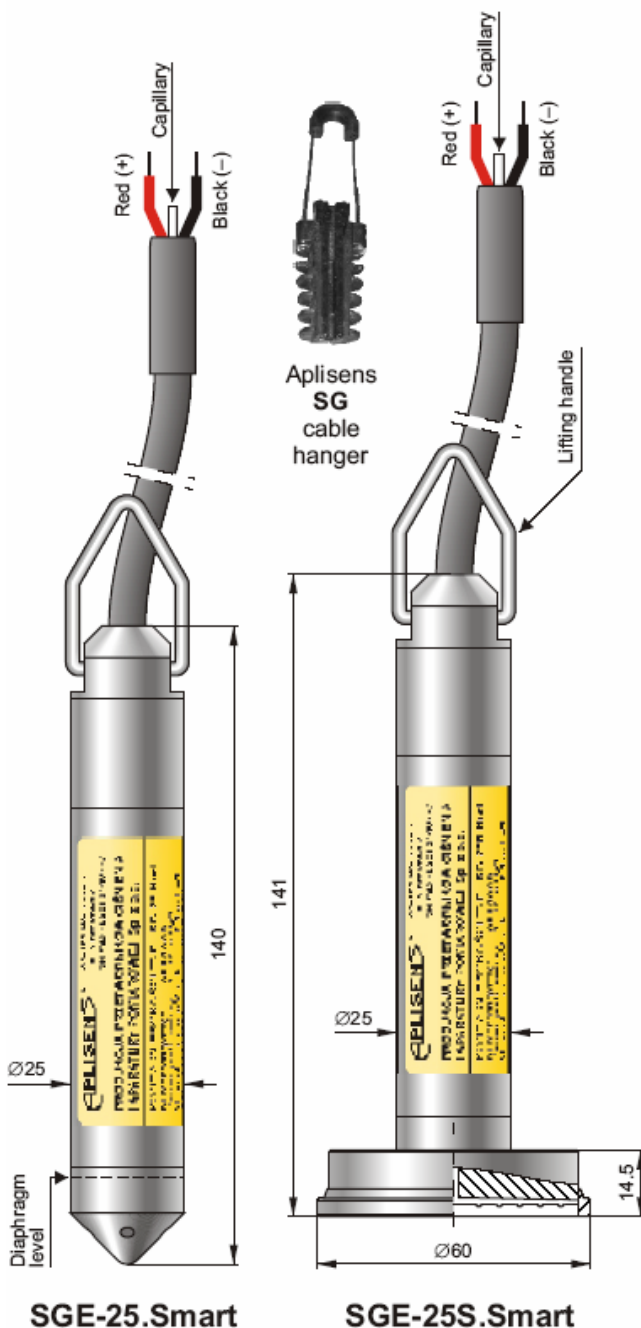

SGE-25.Smart

SGE-25S.Smart

## Installation, method of use

When lowered to the reference level, the probe may either hang freely on the cable or lie on the bottom of the tank. The cable with the capillary can be extended using a standard signal cable. For the cable connection a special Aplisens **SG** cable hanger is recommended. The cable connection should be situated in a non-hermetically sealed box (the internal pressure inside the box should be equal to the atmospheric pressure), preventing water or other contaminants from getting into the capillary. The Aplisens **PP** junction box is recommended. For systems with long signal transmission lines, it is recommended the using of an addi-

tional Aplisens UZ-2 overvoltage protection circuit in the form of a wall-mounted box which allows the cables connection. When the probe cable is being wound up, the minimum winding diameter should be 30cm and the cable should be protected from mechanical damage.

If there is a possibility of turbulence in the tank (for example, because of the mixer operating mixers or a turbulent inflow), the probe should be installed inside a screening tube (e.g. made of PVC). The line hooked on the lifting handle can simplify the operation of the probe pulling out. Cleaning the probe diaphragm by mechanical means is strictly prohibited.

## Measuring ranges

No.	Nominal measuring range (FSO)	Maximum range (measurement limit)	Minimum set range	Overpressure limit (without hysteresis)
1	0...10 m H <sub>2</sub> O	-1...11.5 m H <sub>2</sub> O	0.8 m H <sub>2</sub> O	100 m H <sub>2</sub> O
2	0...100 m H <sub>2</sub> O	-5...115 m H <sub>2</sub> O	8 m H <sub>2</sub> O	700 m H <sub>2</sub> O

## Technical data

### Metrological parameters

**Accuracy** ≤ ±0.1% for nominal range  
**SGE-25.Smart** ≤ ±0.3% for range 0...10% FSO  
**Long term stability** ≤ 0.1% (FSO) for 2 years  
**Accuracy** ≤ ±0.16% for nominal range  
**SGE-25S.Smart** ≤ ±0.4% for range 0...10% FSO  
**Thermal error** < ±0.08% (FSO) / 10°C  
 max ±0.25% in the whole compensation temp. range

For the SGE-25S.Smart probe the use of a diaphragm seal causes an additional absolute zero error, related to changes in the medium temperature, of up to 80 Pa / 10°C

**Thermal compensation range** -25...80°C  
**Time Constant** 0.3 s  
**Additional electronic damping** 0...30 s  
**Error due to supply voltage changes** 0.002% (FSO) / V

### Special versions:

- ◇ **EEx** – ATEX Intrinsic safety
- ◇ **Teflon** – Teflon cable shielding
- ◇ **1.5 m H<sub>2</sub>O** – Probe for nominal range 0...1.5 m H<sub>2</sub>O (Accuracy 0.16%)

### Electrical parameters

**Power supply** 10.5...36 V DC (EEx 12...28 V DC)  
**Output signal** 4...20 mA (two wire transmission)  
**Load resistance**  $R[\Omega] \leq \frac{U_n[V] - 10.5V}{0.02A} - 0.85$   
**Resistance required for communication** 250...1100 Ω

### Operating conditions

**Medium temperature range**  
 -30...80°C for basic range 0...10 m H<sub>2</sub>O  
 -30...50°C for basic range 0...100 m H<sub>2</sub>O  
**CAUTION:** The medium must not be allowed to freeze in the immediate vicinity of the probe.

**Degree of protection** IP-68  
**Material of casing and diaphragm** 00H17N14M2 (316Lss)  
**Cable shield** POLYURETHANE

## Ordering procedure

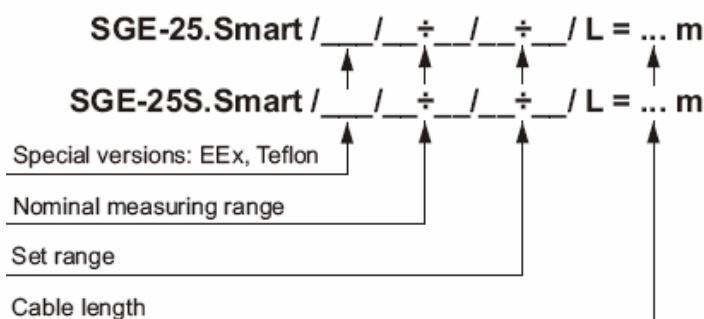

Fitting accessories if required: **SG** cable hanger, **PP** junction box

**Example:** SGE-25.Smart probe, Teflon cable shielding, nominal measuring range 0 ÷ 10 m H<sub>2</sub>O, set range 0 ÷ 3.25 m H<sub>2</sub>O, cable 10 m

**SGE-25.Smart / Teflon / 0 ÷ 10 m H<sub>2</sub>O / 0 ÷ 3.25 m H<sub>2</sub>O / L = 10 m**

## The manner of communicator connection

