

Multihole PITOT tubes are used to measure flow in big pipes when a great accuracy is not required.

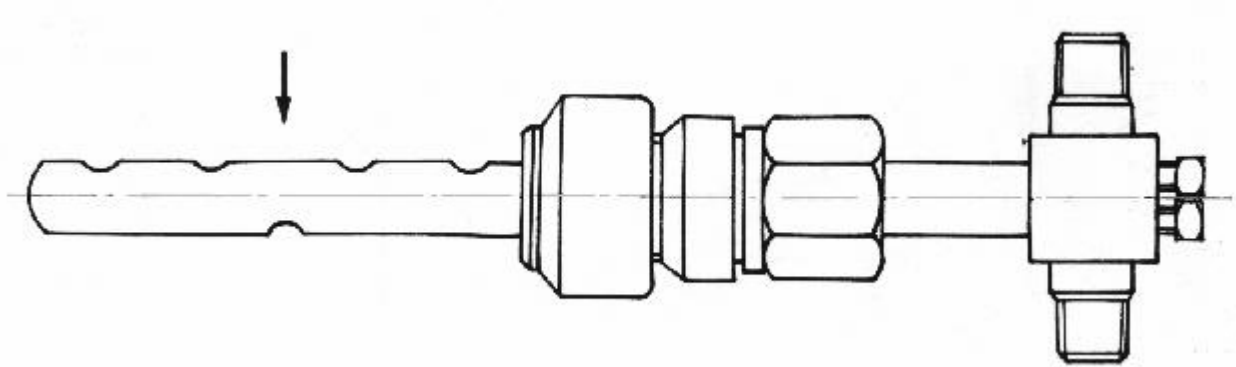

Is recommended for pipe from DN200 to DN1500 and it is standard equipped with: AISI 316 SS material instrument connections \varnothing 1/2" NPT-M. Process connection \varnothing 1" NPT-M and carbon steel half couplings.

Flow Calculation

For flow calculation it is necessary to specify:

- Metered fluid and its state
- Maximum flow
- Normal flow
- Minimum flow
- Operating temperature
- Base temperature
- Operating pressure
- Base pressure
- Barometric pressure
- Pipe diameter
- Type of meter (dry type, mercury type)
- Specific gravity at base and operating conditions. Gases should be related to air
- Absolute viscosity in "centipoises" at operating conditions
- Super compressibility factor