

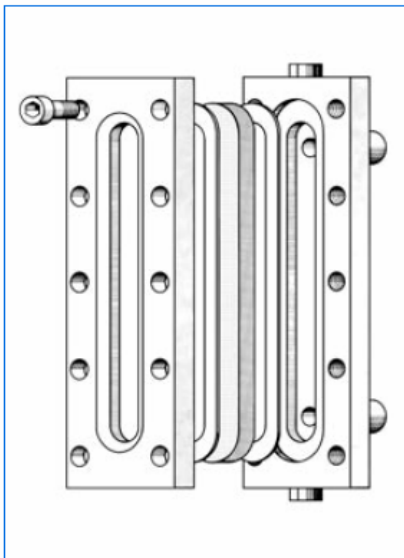

Rectangular sightglass fittings TÜV-approved Series RSG / RSGR / RSGRR Sizes 170 - 1000



Rectangular sightglass fitting, series RSGRR,
size 250, with reflex glass



Application:

Rectangular VETROLUX® sightglasses of the series RSG / RSGR / RSGRR may be used to observe the interior of reactors, columns, silos, vessels, storage tanks and pipelines. They serve mainly as liquid level gauges. They are delivered ready to be welded into or onto a vessel wall, complete with the appropriate seals, glass plates, and cover fastenings.

Operating conditions:

Nominal pressure 16 bar

Vacuum

Note: The nominal pressure indicated refers to the design base of the sightglass. When welded into the vessel concerned, the base frame becomes part of the vessel wall. It is necessary, therefore, that appropriate strength calculations are made on all vessels concerned with respect to the design pressure and size of the vessel and in accordance with the relevant design code. If found to be necessary, reinforcement of the vessel wall has to be carried out.

Operating temperatures:

100 °C max. with sodium silicate glass to DIN 8903

243 °C max. with borosilicate glass to DIN 7081

Note: The above indicated temperatures refer to the use of unprotected glass plates, with no protective mica sheets.

Standard materials:

Base frame: RSt 37-2 or H11 (boiler plate) / AISI 316 Ti stainless steel

Cover frame: As base frame

Glass plate: Toughened sodium silicate glass to DIN 8903 (max. 100 °C)
Toughened borosilicate glass to DIN 7081 (max. 243 °C)

Gaskets: KLINGERSil C4400 / Neoprene
PTFE / Viton

Cover fastenings: Steel, quality 8.8 / Stainless steel
Other materials on request.

Certificates:

Against extra charge, material certificates to DIN 50049, 3.1A / 3.1B or 3.1B AD-W2 as well as glass certificates to DIN 50049, 2.2 may be supplied. Please specify on enquiry.

Options:

- Version with closed base frame (drawing left) to be used as an external liquid level gauge with top and bottom pipe connections. For this application, the base frame will be supplied appropriately drilled and tapped.
- Radiused base frame to suit vessel wall
- Clear (transparent) glass plate
- Alternative versions in shape and size

Remarks:

The TÜV approval does **not** apply to the base flange as this is considered as part of the vessel wall after welding. Standard delivery includes a reflex (fluted) glass plate. In circumstances where a clear (transparent) glass plate is required, this must be **clearly stated** at the time of enquiry.

After welding into the vessel, the base frame should be checked to ensure that the sealing surface is flat and has not become distorted to avoid possible leakage under pressure and / or breakage of the glass plate during tightening of the cover frame bolts. This process should be carried out in several steps and progressively alternating between each pair of opposite bolts from one end of the frame to the other! Tighten first little, then repeat the operation.

Type designation:

- Series RSG: Base and cover frame in steel RSt 37-2
- Series RSGR: Base frame in AISI 316 Ti and cover frame in RSt 37-2
- Series RSGRR: Base and cover frame in AISI 316 Ti

Ordering example:

1 piece rectangular sightglass, base frame in AISI 316 Ti, cover frame in RSt 37-2, length 350 mm, glass plate in sodium silicate glass to DIN 8903, fluted (Reflex), gasket product side PTFE, cover side Neoprene, cover fastenings 8.8 zinked:
1 piece type RSGR-350, 1.4571 - PTFE - 8903 R - Neoprene - RSt 37-2 - 8.8 zink.



Survey of standard types Dimensions

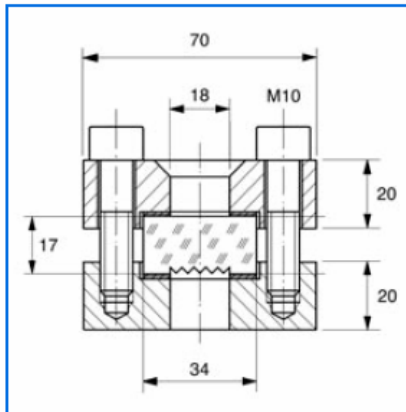

Depending on the overall length of the sightglass, the cover frames are made to a maximum unit length A, and the base frame interrupted by bridges which correspond to this length. This strengthens the base frame and reduces the maximum length of the individual glass pieces required to cover the whole length, thus reducing the possibility of glass breakages when the cover frames are tightened down. When selecting the overall length of the sightglass, and the number of units this will involve, due note should be taken to ensure that the liquid level to be observed normally falls into one of the visible sections. (If this is not possible, then consult us for our series of D-ended sightglasses LSG / LSGR / LSGRR)

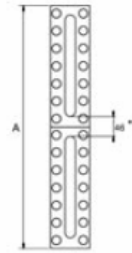

* 36 for size 700

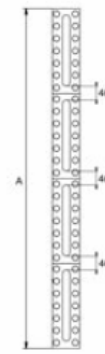

Size(s)	170 - 400	500 - 800	1000
---------	-----------	-----------	------

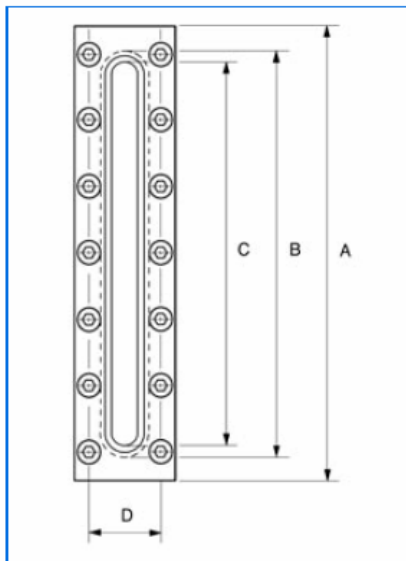

Type	Size	Length A	Number of units	Free view C	Glass-length B	Bolts		Weight (kg)
						number	D	
RSG RSGR RSGRR	170	170	1	124	140	8	50	2,70
RSG RSGR RSGRR	250	250	1	204	220	10	50	4,40
RSG RSGR RSGRR	300	300	1	264	280	14	50	5,00
RSG RSGR RSGRR	350	350	1	304	320	16	50	6,00
RSG RSGR RSGRR	400	400	1	354	370	18	50	7,00
RSG RSGR RSGRR	500	500	2	2 x 204	2 x 220	20	50	9,10
RSG RSGR RSGRR	600	600	2	2 x 264	2 x 280	28	50	10,50
RSG RSGR RSGRR	700	700	2	2 x 304	2 x 320	32	50	12,00
RSG RSGR RSGRR	800	800	2	2 x 354	2 x 370	36	50	14,00
RSG RSGR RSGRR	1000	1000	4	4 x 204	4 x 220	40	50	17,00

Branch office / exclusive agent:

All dimensions in mm. Subject to changes without preliminary notice.