



Disc check valve with centering ring for placing between flanges in accordance with DIN, UNE, ANSI, BS, etc. norms.

DN-125 to 200 (DN-15 to 100 see catalogue for Model 170).

For liquids, gases and steam.

For use in hydraulic, pneumatic, heating and steam systems, chemical and food industries, etc.

Specifications

- Reduced assembly time in accordance with DIN-3202, part 3, series K4.
- Minimum load loss.
- Avoids ram shock when closing at zero pressure, remaining completely tightness at the time of fluid reversion.
- Highly watertight, exceeding the requirements of DIN-3230. Page 3.
- Easily assembled in any position in accordance with the direction of the fluid flow. Without spring only in vertical ascending direction.
- The valves have one single centering ring for placing between flanges according to DIN and UNE norms (PN-6, 10, 16, 25 and 40), ASA (ANSI) (PSI-150 and 300) and other norms (NF, BS, etc.).

IMPORTANT

Depending on demand:

- Possibility of manufacture in other types of material, for use in special working conditions (high temperatures, fluids, etc.).

N.º PIECE	PIECE	MATERIAL											
		BRONZE				CAST STEEL				STAINLESS STEEL			
1	Body	Bronze (DIN-2.1086.01 G-CuSn10Zn)				Cast steel (DIN-1.0619 GS-C 25)				S. steel (DIN-1.4408)(ASTMA351 CF8M)			
2	Sealing	Bronze (DIN-2.1086.01 G-CuSn10Zn)				S. steel (DIN-1.4408)(ASTM A351 CF8M)				S. steel (DIN-1.4408)(ASTMA351 CF8M)			
3	Sealing disc	Bronze (DIN-2.1086.01 G-CuSn10Zn)				S. steel (DIN-1.4408)(ASTM A351 CF8M)				S. steel (DIN-1.4408)(ASTMA351 CF8M)			
4	Lead	Bronze (DIN-2.1086.01 G-CuSn10Zn)				S. steel (DIN-1.4408)(ASTM A351 CF8M)				S. steel (DIN-1.4408)(ASTMA351 CF8M)			
5	Spring	S. steel (DIN-1.4571)(AISI-316Ti)				S. steel (DIN-1.4571)(AISI-316Ti)				S. steel (DIN-1.4571)(AISI-316Ti)			
6	Centering ring	S. steel (DIN-1.4300)(AISI-302)				S. steel (DIN-1.4300)(AISI-302)				S. steel (DIN-1.4300)(AISI-302)			
DN		125 to 200											
PN		16				40				40			
OPERATING CONDITIONS	PRESSURE IN bar	16	15	14	13	40	35	28	21	40	34	32	29
	MAXIMUM TEMP. IN °C	120	180	200	250	120	200	300	400 (1)	120	200	300	400 (1)
	MINIMUM TEMP. IN °C	-60				-10				-60			

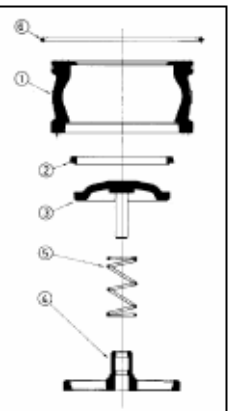

(1) For temperatures exceeding 300°C without spring only or depending on demand, with special spring.

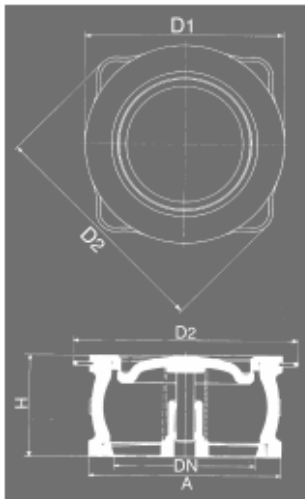

DN		125	150	200
H		90	106	140
A		180	205	262
D ₁		180	205	262
D ₂		205	240	300
WEIGHT IN Kg.	BRONZE	8,13	12,05	21,66
	CAST STEEL	6,90	10,78	19,13
	STAINLESS STEEL	6,93	10,83	19,21
CODE	BRONZE	2003-172.5501	2003-172.5601	2003-172.5801
	CAST STEEL	2003-172.8504	2003-172.8604	2003-172.8804
	STAINLESS STEEL	2003-172.8502	2003-172.8602	2003-172.8802

		OPENING PRESSURE IN mbar								FLOW COEFFICIENT	
		WITHOUT SPRING				WITH SPRING				Kv m ³ /h ΔP= 1 bar	Cv l/min ΔP= 1 Psi =0,07 bar
		▲		▲		▶		▼			
DIRECTION OF FLUID FLOW	BRONZE	C. STEEL S. STEEL	BRONZE	C. STEEL S. STEEL	BRONZE	C. STEEL S. STEEL	BRONZE	C. STEEL S. STEEL			
DN	125	8,40	7,50	28,40	27,50	22,00	11,60	12,50	210,00	700,00	
	150	11,70	10,50	31,70	30,50	24,00	8,30	9,50	349,00	1250,00	
	200	13,00	11,60	33,00	31,60	24,00	7,00	8,40	640,00	2340,00	

Load losses

The adjoining diagram reflects the load loss curves for water at 20°C. Values are based on valves without springs and installed horizontally. In the case of vertical flow, the variations are virtually unimportant. In order to determine other fluids load losses, calculate the flow of these equivalent to water.

$$Q_A = \sqrt{\frac{\rho}{1.000}} \cdot Q$$

- Q_A = Flow equivalent to water in m³/h.
- ρ = Fluid density in operating conditions in Kg/m³.
- Q = Fluid flow in operating conditions in m³/h.

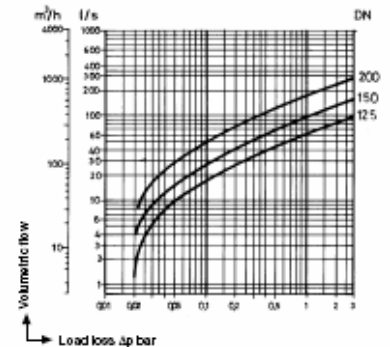

Informative brochure, without obligation and subject to our General Sales Conditions.